



## INSTALLATION/OPERATION/MAINTENANCE MANUAL for the FlowMax® REGULATOR

### SCOPE

This manual provides instructions for the Installation, Operation, and Maintenance of the **FlowMax® Regulator** (instructions for the Series 20 and 20L Pilots can be found in separate manuals). This manual is divided into the following sections:

<b>Product Description</b> . . . . .	<b>1</b>
<b>Principle of Operation</b> . . . . .	<b>2</b>
<b>Regulator Markings</b> . . . . .	<b>3</b>
<b>Nameplate Information</b> . . . . .	<b>3</b>
<b>Hydrostatic Testing</b> . . . . .	<b>4</b>
<b>Installation</b> . . . . .	<b>5-6</b>
<b>Piping Schematics</b> . . . . .	<b>6-12</b>
<b>Start-up and Operation</b> . . . . .	<b>13-15</b>
<b>Maintenance</b> . . . . .	<b>16-27</b>
<b>Bolt Torque Specifications</b> . . . . .	<b>27</b>
<b>Troubleshooting</b> . . . . .	<b>28</b>
<b>Warranty</b> . . . . .	<b>28</b>



The 2" FlowMax® Regulator with a Series 20 Pilot and Type 30A Filter.

### PRODUCT DESCRIPTION

The FlowMax® is an easy to maintain regulator designed to be used with a self-contained pilot system. The FlowMax® Regulator has several unique features that add to its versatility, such as:

- In-line maintenance
- A single Maximum Pressure Rating for all components
- One Actuator for all pressures and differentials
- A compact, low-volume actuator housing for quick response and lightweight design
- Top-entry design
- Maximum flow at a low differential
- Increased closing force with an increase in inlet pressure

### MATERIALS OF CONSTRUCTION

Body	ASTM A 395 Ductile Iron
Actuator Housing	A 356-T 6 Cast Aluminum
Spring Case	A 356-T 6 Cast Aluminum
Plug	Nitrile
Diaphragms	Nitrile/Nylon
O-Ring & Seals	Nitrile
Bolting	ASTM B 8 or Equal
Spring	Music Wire

Table 1

### SPECIFICATIONS

Sizes	2,3,4 and 6 Inch	
Body Style	Single Port	
End Connections	150 CL FF, 150 CL RF Flanged, NPT (2" Only)	Contact Factory
Temperature	Working -20°F to 150°F Emergency -40°F to 175°F	Working -28°C to 65°C Emergency -20°F to 150°F
Maximum Operating Differential	250 psig	17.6 kg/cm <sup>2</sup>
Max Casing Pressure	250 psig	17.6 kg/cm <sup>2</sup>
Minimum Differential (Fully Open)	3 psi	0.20 kg/cm <sup>2</sup>
Outlet Pressure	Series 20L: 5 i.w.c. to 8 psi	.01 to .56kg/cm <sup>2</sup>
Range	Series 20: 3 psi to 248 psi	.2 to 17.4 kg/cm <sup>2</sup>
Pilot Supply Body Tap	One 1/4" - 18 NPT	
Sense Line Tap	Two 1/2" - 14 NPT	

Table 2

## PRINCIPLE OF OPERATION

When the downstream pressure is greater than the set point of the pilot, the pilot is closed, resulting in equal pressure above and below the main diaphragm. With a balancing diaphragm area slightly larger than the seat area, the resulting closing force, along with the force of the main spring, forces the plug against the seat.

With an increase in demand, the outlet pressure will begin to drop and decrease the pressure above the main diaphragm. The drop of the outlet pressure below the pilot set point will cause the pilot to open. As the pilot opens, pressure increases underneath the main diaphragm faster than pressure can bleed through the internal restrictor. The imbalance in pressure on the main diaphragm overcomes the spring force and the additional closing force from the balancing diaphragm, causing the plug to rise off the seat and satisfy the flow demand.

Once the flow demand is satisfied and the downstream pressure begins to increase, the pressure above the main diaphragm and in the pilot sense cavity rises. This causes the pilot to close. The pressure below the main diaphragm bleeds through the internal restrictor until pressure equalizes above and below the main diaphragm. The forces of the main spring and the oversized balancing diaphragm then close the plug on the seat.

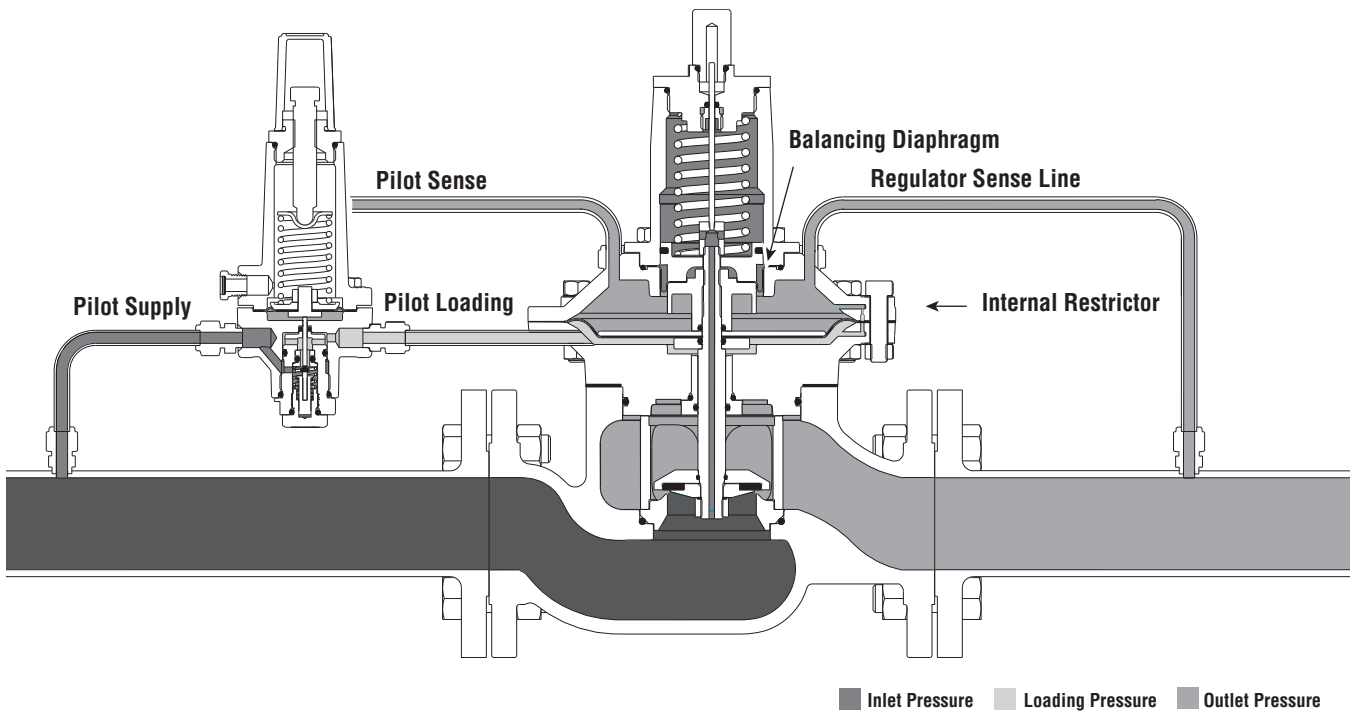

Fig. 1

## NAMEPLATE INFORMATION

Item	Definition
FlowMax®	Trademarked name
SN	Serial number assigned to regulator
FM #	FlowMax® product identification
SIZE/END CONN	Line size of body and type of end connection
MAX INLET/OUTLET	Maximum inlet pressure
OUTLET	Maximum outlet pressure
CAP %	Percent capacity of maximum for the regulator
MFG DATE	Date of manufacture
MIN DIFF	Minimum differential required to fully open regulator
MAX TEMP	Maximum Operating Temperature in degrees

**mooney FlowMax®**

S/N  FM #

○ SIZE/END CONN:  ○

MAX INLET/OUTLET  PSIG CAP  %

MFG DATE  MIN DIFF  PSI

MAX TEMP: 175° / 80°C

Fig. 2

## REGULATOR MARKINGS AND PORT IDENTIFICATION

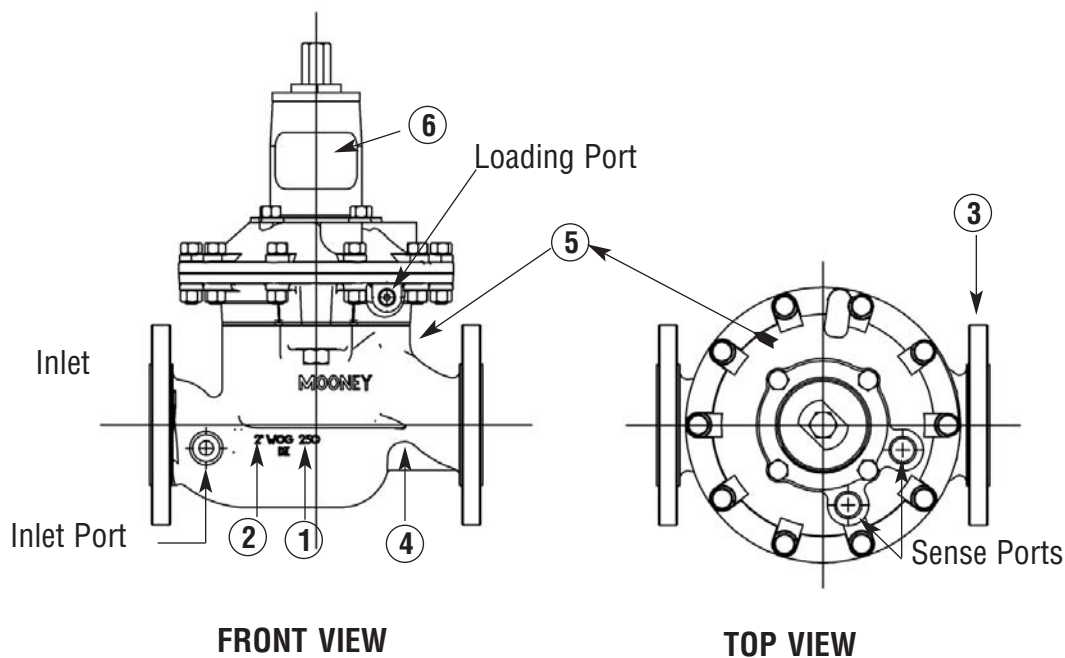

Fig. 3

1. American National Standards Institute (ANSI) pressure class rating of the regulator.
2. Line size of body.
3. ANSI pressure class rating of the flanges.
4. Indication that the regulator has been hydrostatically tested to Code requirements.
5. The Serial Number is stamped on the Actuator Housing, Regulator Body, and Nameplate.
6. The Nameplate location.

## HYDROSTATIC TESTING

### WARNING

Installation and testing of the FlowMax® Regulator should be made by trained, qualified personnel familiar with high-pressure piping and pilot-operated regulators.

All FlowMax® Regulators are hydrostatically tested at the factory prior to shipment according to ISA-S75.19-1989 and MSS-SP-61 standards. If it is necessary to retest the Regulator body, follow the procedures listed below.

**NOTE: This Procedure applies to the Regulator Body only. If Actuator retesting is required, contact the Factory for proper procedures.**

1. Disconnect and remove the Pilot Inlet and Actuator Sense control line(s).
2. Remove the Body-to-Actuator bolts and remove the Actuator and Pilot.

3. Plug the Pilot supply line in the Regulator Body or, if applicable, the Pilot Filter.
4. Remove the Cage, Seat, and O-ring from the Body. **CAUTION! DO NOT DAMAGE THE SEAT SEALING SURFACE (KNIFE-EDGE).**
5. Plug the Flange/Actuator mounting surface on the body.

**NOTE: A plug for hydrostatically testing the Body is available from the Factory (See Figure 4).**

6. Pressurize the system to the required maximum hydrostatic pressure. **DO NOT EXCEED 375 PSIG.**
7. After the Hydrostatic test is completed and the body is dry and clean, follow the Assembly procedures in the MAINTENANCE section of this manual.

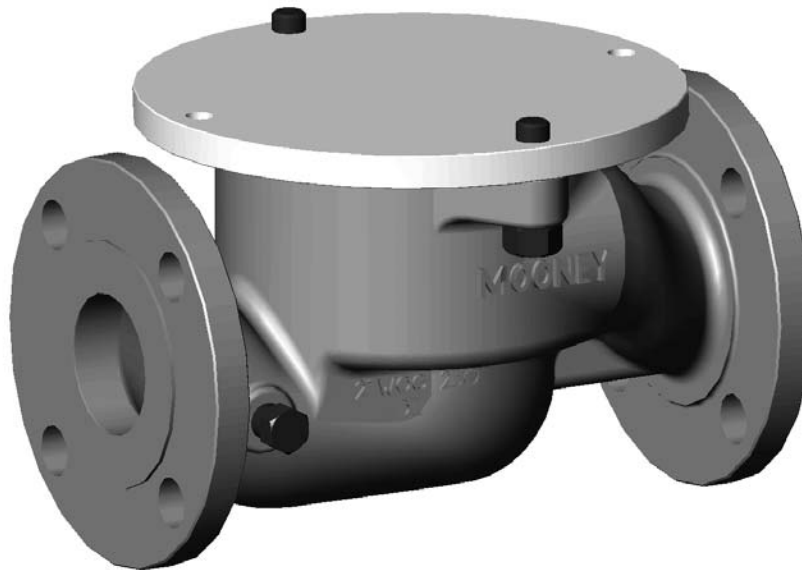

Fig. 4 Installed Hydrostatic Plug.

## INSTALLATION

### WARNING

Personal injury, equipment damage, or leakage due to explosion of accumulated gas or bursting of pressure containing parts may result if this valve/regulator is overpressured or is installed where service conditions could exceed the limits given in the specification of this manual or on the nameplate, or where conditions exceed any ratings of the adjacent piping or piping connections. Verify the limitations of both valve and pilot to ensure neither device is overpressured. To avoid such injury or damage, provide pressure relieving or pressure limiting devices (as required by the U.S. code of Federal Regulations, by the National Fire Codes of the National Fire Protection Association, or by other applicable codes) to prevent service conditions from exceeding those limits. Additionally, physical damage to the regulator, pilot, or tubing can cause personal injury and/or property damage due to explosion of accumulated gas. To avoid injury and damage, install the valve in a safe location.

**NOTE:** The following installation instructions are based upon using Pilots and Filters manufactured by Mooney Controls, GE, Inc. When using equipment from other manufacturers, please contact Mooney Controls or the local Mooney Controls Representative for product compatibility.

- PERSONNEL:** Installation of the FlowMax® Regulator should be performed by trained, qualified personnel familiar with high-pressure piping and Pilot-operated Regulators.
- PRIOR INSPECTION:** Inspect the main Regulator, Pilot, and Tubing for any damage that might have occurred in shipping. Make sure the Body, Pilot Sense lines, and piping are clear and free of foreign material.
- SCREWED END REGULATORS:** Apply a pipe compound to the male threads starting one or two threads back from the end prior to assembling the joint.

- Flanged End Regulators:** Use suitable line gaskets and good bolting practices with flanged bodies. Incremental tightening of the line bolts in a criss-cross pattern is recommended.

### WARNING

Gas Regulators installed in confined or enclosed spaces should be provided with adequate ventilation to prevent the possibility of gas buildup or accumulation from leaks and venting. Leaks or vented gas may accumulate causing personal injury, death, or property damage. Pilot spring cases and the regulator enclosure should be vented to a safe area away from air intakes, or any hazardous location. The vent lines and stacks must be protected against condensation and clogging.

- ORIENTATION:** The FlowMax® Regulator may be installed in any position – the best position being the one that provides easiest access for Pilot adjustment and general maintenance.
- CONTROL LINES:** Control Sense lines should be run from the Actuator on the FlowMax® Regulator to a point 8 to 10 pipe diameters downstream from the regulator (refer to Piping Schematics). Use Table 3 as a guide for the ideal tubing size to use. Reduce as necessary to connect the Actuator.

	Outlet Pressure		
	Inches to 2 psi	2 psi to 5 psi	5 psi & above
Pilot Regulator with:			
Static Sense Line (No Flow)*	1/2" Pipe minimum	1/2" Tubing	3/8" Tubing
Sense Line with Flow**	3/4" to 1" Pipe	1/2" Pipe	1/2" Tubing

Table 3

\*The FLOWGRID® Series 20 Pilot has a static sense line.

\*\* The Sense line of the FlowMax Actuator has flow.

**NOTE:** The Control line connection should be away from areas of turbulence (such as valves, reducers, and elbows) and should have a full opening into the pipe free from burrs, drill peels, and weld slag. Shutoff valves may be required in the control line(s), if installed, they should be of the full opening type.

## INSTALLATION (cont'd)

7. **PILOT SUPPLY LINES:** Run a 3/8-inch or 1/2-inch Pilot supply line from the upstream piping or from the Inlet Port body connection on the side of the FlowMax® Regulator to the Pilot Inlet port.
8. **A FILTER** in the Pilot Supply line is recommended to remove particulates from the Pilot supply that could affect the variable orifice in the Pilot.

**NOTE: A shutoff valve is not required in the Pilot supply line, but if one is installed, it must be a full-opening type.**

9. **VENT VALVES AND GAUGE CONNECTIONS:** Vent valves and gauge connections are recommended in the Inlet and Actuator Sense piping of the FlowMax® Regulator.

10. **INTERSTAGE PIPING:** The recommended length of the interstage piping between monitor regulators is 6 pipe diameters or 36 inches, whichever is greater. It is also recommended that the interstage piping be swaged up 1 pipe diameter over the nominal port size of the valve for Working Monitor applications.

FOR EXAMPLE: A station with two 2" FlowMax® Regulators in a Working Monitor configuration should have interstage piping at least 36 inches in length and swaged up to a 3-inch pipe.

## PIPING SCHEMATICS

The following piping schematics are provided:

1. Single Regulator with Single Pilot. **Page 7**
2. Standby Monitor set with differential pressure **greater** than 10 psid (Monitor located downstream). **Page 8**
3. Standby Monitor set with differential pressure **less** than 10 psid (Monitor located downstream). **Page 9**
4. Standby Monitor set with differential pressure **greater** than 10 psid (Monitor located upstream). **Page 10**
5. Standby Monitor set with differential pressure **less** than 10 psid (Monitor located upstream). **Page 11**
6. Working Monitor set. **Page 12**

All drawings show installations with the Series 20 Flowgrid® Pilot. Consult factory for installation schematics of other manufacturer's pilot on the FlowMax® Regulator.

## NOTES:

---

---

---

---

---

---

---

---

---

---

---

---

---

---

---

---

---

---

---

---

---

## PIPING SCHEMATICS (cont'd)

### Single Regulator/ Single Pilot (Pressure Reducing Valve)

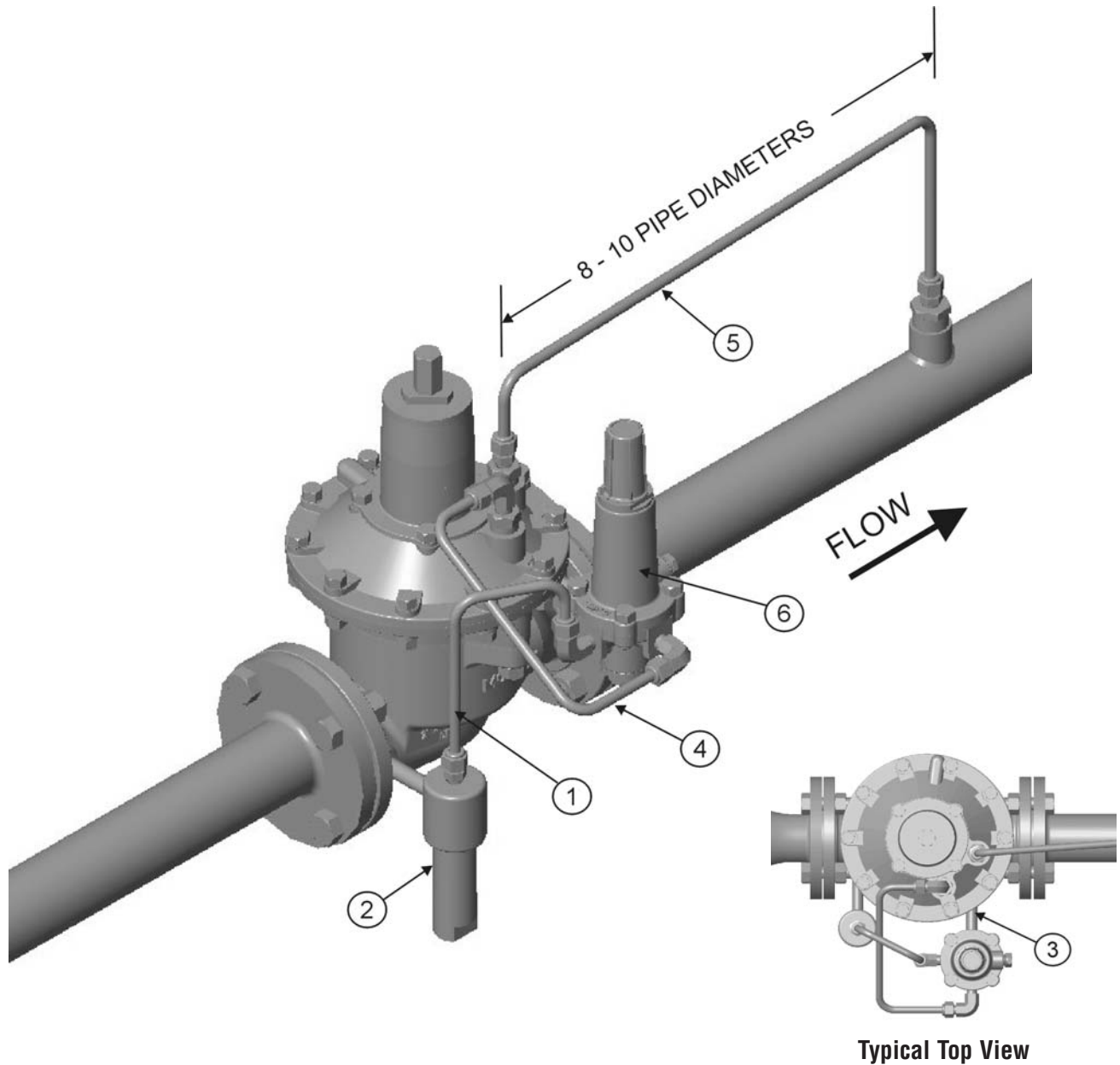

1. Pilot supply tubing from Filter OUTLET connection to the Series 20 Pilot INLET Port.
2. Type 30 Filter mounted in Inlet Piping.
3. OUTLET Port of Series 20 Pilot connected to Loading connection on the Actuator Housing of the FlowMax® Regulator
4. Sense line connecting the SENSE Port on the Series 20 Pilot to the Sense Port on the FlowMax® Actuator. (Refer to Table 3 on Page 5 for Sense piping recommendations)
5. Sense line connecting the FlowMax® Regulator to the downstream piping.
6. Series 20 Pilot with pilot cartridge in PRV mode. Pilot LOADING Port is plugged.

## PIPING SCHEMATICS (cont'd)

Standby Monitor with Differential Pressure Greater than 10 psid  
(Monitor located downstream)

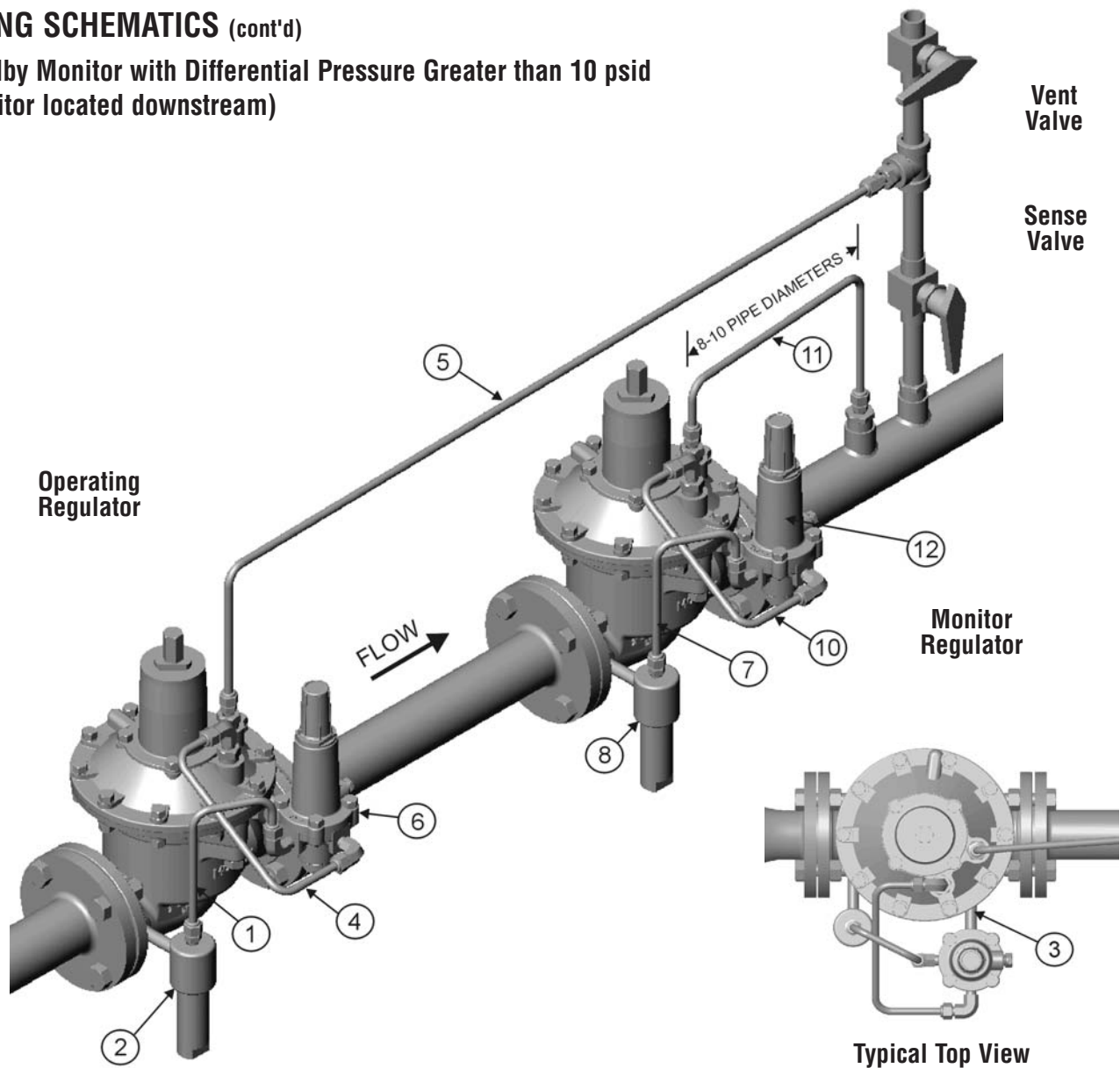

1. Pilot supply tubing from Filter OUTLET to Series 20 Pilot INLET Port.
2. Type 30 Filter mounted in Inlet Piping.
3. OUTLET Port of Series 20 Pilot connected to the Loading connection on the Actuator Housing of the FlowMax<sup>®</sup> Regulator.
4. Sense line connecting the SENSE Port on the Series 20 Pilot to the Sense Port on the FlowMax<sup>®</sup> Actuator. (Refer to Table 3 on Page 5 for Sense piping recommendations)
5. Sense line connecting the FlowMax<sup>®</sup> Regulator to the downstream piping.
6. Series 20 Pilot with pilot cartridge in PRV mode. Pilot LOADING Port is plugged.
7. Pilot supply tubing from Filter OUTLET to Series 20 Pilot INLET Port.
8. Type 30 Filter mounted in Inlet Piping.
9. OUTLET Port of Series 20 Pilot connected to the Loading connection on the Actuator Housing of the FlowMax<sup>®</sup> Regulator (Same as #3, See Typical Top View).
10. Sense line connecting the SENSE Port on the Series 20 Pilot to the Sense Port on the FlowMax<sup>®</sup> Actuator.
11. Sense line connecting the FlowMax<sup>®</sup> Actuator to the downstream piping.
12. Series 20 Pilot with pilot cartridge in PRV mode. Pilot LOADING Port is plugged.



## PIPING SCHEMATICS (cont'd)

Standby Monitor with Differential Pressure Less than 10 psid  
(Monitor located downstream)

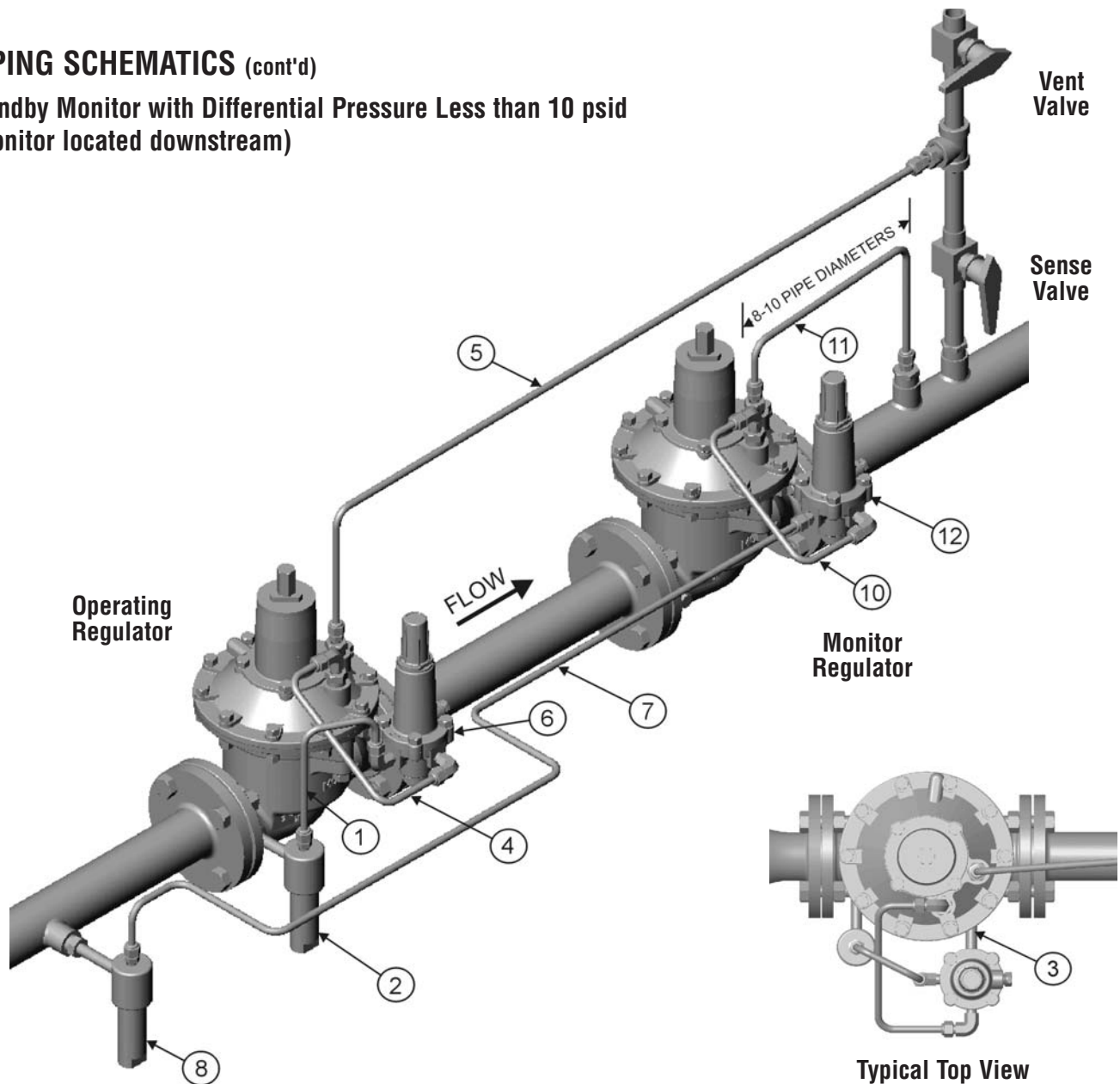

1. Pilot supply tubing from Filter OUTLET connection to Series 20 Pilot INLET Port.
2. Type 30 Filter mounted in Inlet Piping.
3. OUTLET Port of Series 20 Pilot connected to the Loading connection on the Actuator Housing of the FlowMax® Regulator.
4. Sense line connecting the SENSE Port on the Series 20 Pilot to the Sense Port on the FlowMax® Actuator. (Refer to Table 3 on Page 5 for Sense piping recommendations)
5. Sense line connecting the FlowMax® Regulator to the downstream piping.
6. Series 20 Pilot with pilot cartridge in PRV mode. Pilot LOADING Port is plugged.
7. Pilot supply tubing from Filter OUTLET connection on the Upstream piping connected to Series 20 Pilot INLET Port.
8. Type 30 Filter mounted in the Upstream Inlet Piping.
9. OUTLET Port of Series 20 Pilot connected to Loading connection on the Actuator Housing of the FlowMax® Regulator (Same as #3, See Typical Top View).
10. Sense line connecting SENSE Port on Series 20 Pilot to Sense Port on the FlowMax® Actuator.
11. Sense line connecting the FlowMax® Actuator to the downstream piping.
12. Series 20 Pilot with pilot cartridge in PRV mode. Pilot LOADING Port is plugged.

## PIPING SCHEMATICS (cont'd)

Standby Monitor with Differential Pressure Greater than 10 psid  
(Monitor located upstream)

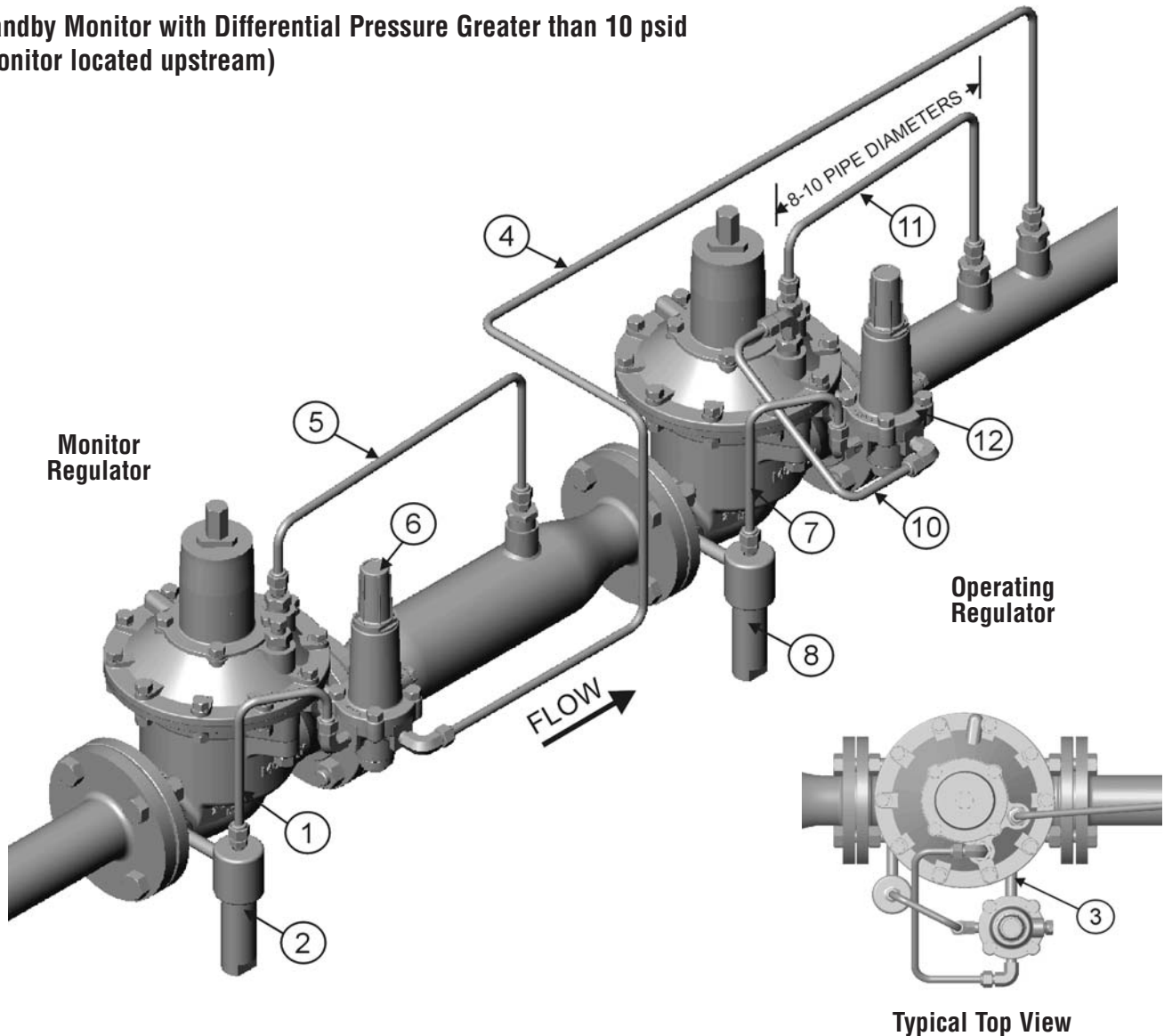

1. Pilot supply tubing from Filter OUTLET connection to Series 20 Pilot INLET Port.
2. Type 30 Filter mounted in Inlet Piping.
3. OUTLET Port of Series 20 Pilot connected to the Loading connection on the Actuator Housing of the FlowMax® Regulator.
4. Sense line connecting the SENSE Port on the Series 20 Pilot to downstream of the Operating Regulator. (Refer to Table 3 on Page 5 for Sense piping recommendations)
5. Sense line connecting the FlowMax® Regulator to the interstage piping.
6. Series 20 Pilot with pilot cartridge in PRV mode. Pilot LOADING Port is plugged.
7. Pilot supply tubing from Filter OUTLET connection to Series 20 Pilot INLET Port.
8. Type 30 Filter mounted in Inlet Piping.
9. OUTLET Port of Series 20 Pilot connected to Loading connection on the Actuator Housing of the FlowMax® Regulator (Same as #3, See Typical Top View).
10. Sense line connecting SENSE Port on Series 20 Pilot to Sense Port on the FlowMax® Actuator.
11. Sense line connecting the FlowMax® Actuator to the downstream piping.
12. Series 20 Pilot with pilot cartridge in PRV mode. Pilot LOADING Port is plugged.

## PIPING SCHEMATICS (cont'd)

Standby Monitor with Differential Pressure Less than 10 psid  
(Monitor located upstream)

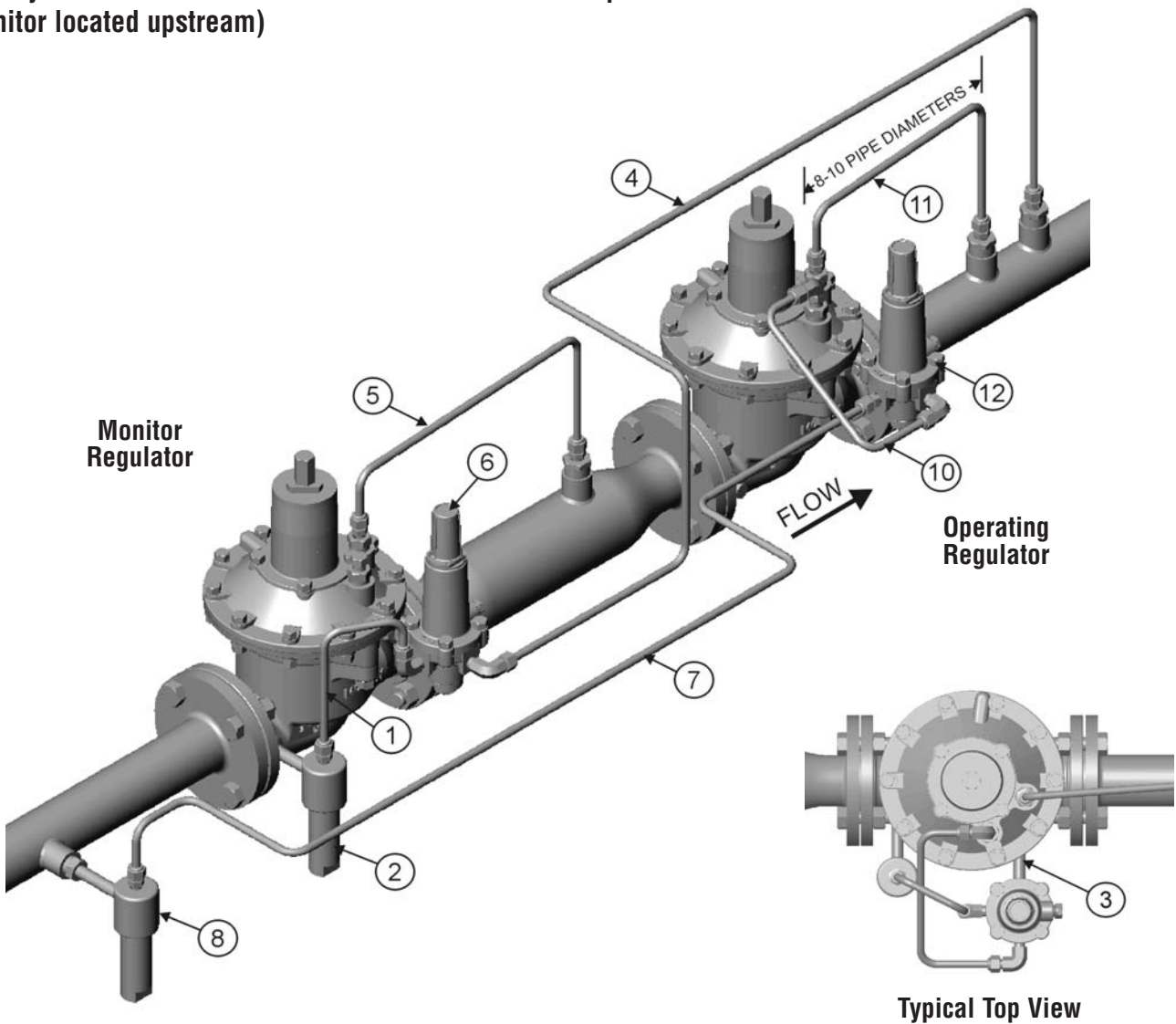

1. Pilot supply tubing from Filter OUTLET connection to Series 20 Pilot INLET Port.
2. Type 30 Filter mounted in Inlet Piping.
3. OUTLET Port of Series 20 Pilot connected to the Loading connection on the Actuator Housing of the FlowMax® Regulator.
4. Sense line connecting the Pilot SENSE port to downstream of the Operating Regulator. (Refer to Table 3 on Page 5 for Sense piping recommendations)
5. Sense line connecting the FlowMax® Regulator to the interstage piping.
6. Series 20 Pilot with pilot cartridge in PRV mode. Pilot LOADING Port is plugged.
7. Pilot supply tubing from Filter OUTLET connection on the Upstream piping to Pilot INLET Port connection.
8. Type 30 Filter mounted in Inlet Piping.
9. OUTLET Port of Series 20 Pilot connected to Loading connection on the Actuator Housing of the FlowMax® Regulator (Same as #3, See Typical Top View).
10. Sense line connecting SENSE Port on Series 20 Pilot to Sense Port on the FlowMax® Actuator.
11. Sense line connecting the FlowMax® Actuator to the downstream piping.
12. Series 20 Pilot with pilot cartridge in PRV mode. Pilot LOADING Port is plugged.

## PIPING SCHEMATICS (cont'd)

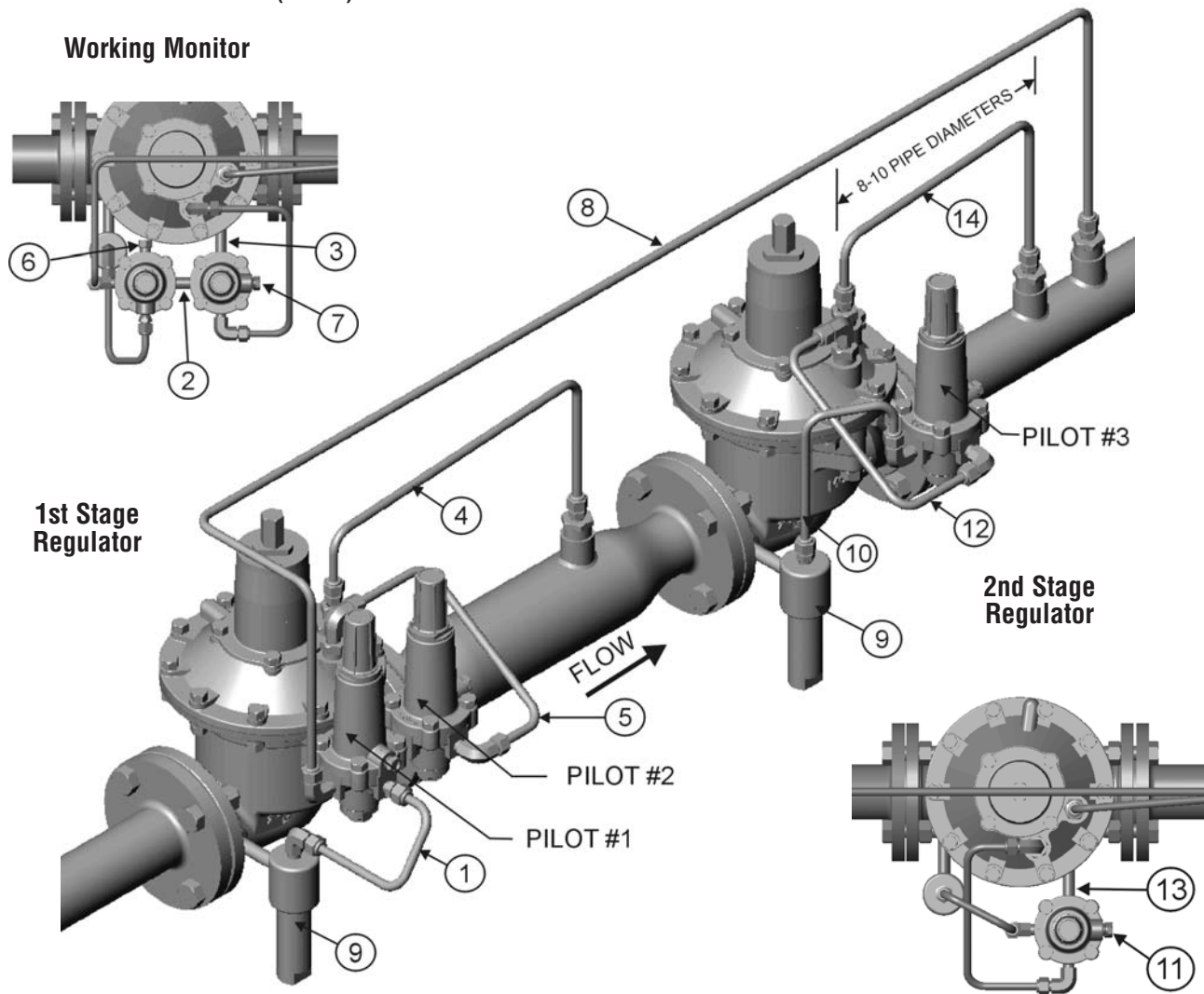

1. Pilot supply tubing from Filter OUTLET connection to Series 20 Pilot (#1) LOADING Port.
2. Pilot #1 OUTLET Port connected to Pilot #2 INLET Port.
3. Pilot #2 OUTLET Port connected to the Loading connection on the Actuator Housing of the FlowMax® Regulator.
4. Sense line connecting the 1st Stage FlowMax® Regulator to the Interstage piping. (Refer to Table 3 on Page 5 for Sense piping recommendations)
5. Sense line connecting SENSE Port on Series 20 Pilot (#2) to the Sense Port on the FlowMax® Actuator.
6. INLET Port on the Monitor Series 20 Pilot (#1) is plugged.\*
7. LOADING Port on the Series 20 pilot (#2) is plugged.\*
8. Sense line connecting the SENSE Port on the Monitor Pilot (#1) to the downstream piping.
9. Type 30 Filter mounted in the Inlet piping.
10. Pilot supply tubing from Filter OUTLET connection to Series 20 Pilot (#3) INLET Port.
11. LOADING Port on the Series 20 Pilot (#3) is plugged.
12. Sense line connecting SENSE Port on Series 20 Pilot (#3) to the Sense Port on the FlowMax® Actuator.
13. OUTLET Port of Series 20 Pilot (#3) connected to the Loading Connection on the Actuator Housing of the FlowMax® Regulator.
14. Sense line connecting the 2nd Stage FlowMax® Regulator to the downstream piping.

\* The INLET and LOADING Ports form a common port on the Series 20 Pilot

## START AND OPERATION

The following procedures are suggested for start up of the FlowMax® Regulator equipped with Series 20 Pilots. Start up of the FlowMax® Regulator should be made by trained, qualified personnel familiar with high pressure systems and pilot-operated regulators.

### WARNING

**The instruction manual for the PILOT(S) being used should be consulted to insure that the installation and start up instructions for the pilot are followed. Some pilots can be damaged if not installed and put into operation correctly.**

#### Single Pressure Reducing Regulator

1. Back off the pilot adjusting screw to fully remove the spring compression.
2. Slowly open the upstream block valve to pressurize the FlowMax® Regulator and pilot system. The FlowMax® Regulator should lock up (shut off) with zero pressure downstream.
3. Fully open any hand valve(s) in the control line(s) and the Pilot supply line.
4. Slightly open a downstream block valve or open a vent in piping downstream of the FlowMax® Regulator.
5. Slowly increase the pilot spring setting until the desired downstream pressure is achieved.
6. Slowly close the downstream block valve or vent to check the FlowMax® Regulator for lockup (shutoff).
7. Slowly open the downstream block valve to allow full flow.

#### NOTES:

---

---

---

---

---

---

---

---

---

---

## STANDBY MONITOR

### (Upstream Operating Regulator Configuration)

This procedure is based on the first regulator being the Operating regulator and the second regulator being the Monitor regulator.

**NOTE: In this configuration, installation of a shut-off valve and a vent valve are required in the Sense line of the Operating regulator to facilitate testing of the Monitor regulator performance. See Pgs. 8 and 9.**

1. If necessary, purge any pressure in the station.
2. Set Operating regulator pilot (#1) spring at the MAXIMUM setting. The Sense line shut-off valve should be closed and the Sense line vent valve should be open.
3. Set Monitor pilot (#2) spring to the MINIMUM (zero) setting.
4. Slowly open the inlet block valve. Full inlet pressure should be present at the Monitor regulator and the Monitor regulator should be closed.
5. Open any hand valve(s) in the Pilot supply lines on both regulators. The Sense line shut-off valve should remain closed and the Sense line vent valve should remain open (Refer to page 8).
6. Open a vent or downstream block valve.
7. Increase the Pilot spring setting of the Monitor Regulator until the desired monitor override setting is reached. Lock in the pilot setting.
8. With some flow going through the station, close the vent valve on the Operating regulator Sense line and open the shut-off valve on the same line. Start to lower the Pilot setting of the Operating regulator until the desired outlet pressure is achieved.

**NOTE: When the set point of the Operating regulator becomes less than the set point of the Monitor regulator, the interstage pressure will drop from approximately full inlet pressure to 2-4 PSI above the outlet pressure at low flow rates.**

#### Checking Standby Monitor Operation

1. With flow going through the station, slowly open the vent valve installed in the Operating regulator Sense line while closing the shutoff valve in the same line. The outlet pressure should begin to rise as the Operating regulator goes wide open. When the pressure reaches the setpoint of the Monitor Regulator, the Monitor should take control and the interstage pressure should increase to approximately full inlet pressure.

## START AND OPERATION (cont'd)

- Return the system to normal operation by reversing the process with the vent valve being closed while the shut-off valve is returned to the open position. The interstage pressure should drop to 2-4 PSI above the outlet pressure as the Operating Regulator regains control (at low flows).

### NOTES:

---

---

---

---

### Standby Monitor

#### (Upstream Monitor Regulator Configuration)

This procedure is based on the first stage regulator being the Monitor regulator and the second stage regulator being the Operating regulator.

- If necessary, purge any pressure in the station.
- Set first stage Monitor regulator pilot spring at the MAXIMUM setting.
- Set second stage Operating regulator pilot spring to the MINIMUM (zero) setting.
- Slowly open the inlet block valve. Full inlet pressure should be present at the second stage Operating regulator and it should be closed.
- Fully open any hand valve(s) in the control line(s) and the Pilot supply line.
- Open a vent or downstream block valve.
- Increase the set point of the second stage Operating regulator to the desired monitor over-ride set pressure.
- Decrease the Pilot spring setting of the first stage Monitor Regulator until it take control at a set point just below the final desired monitor over-ride set pressure.
- Increase the second stage Operating regulator to the maximum pilot setting.
- Increase the first stage monitor regulator set pressure to the final desired monitor over-ride set point.
- Decrease the Pilot spring setting of second stage Operating regulator until the final set point is achieved.

**NOTE: When the set point of the Operating regulator becomes less than the set point of the Monitor regulator, the interstage pressure will rise to 2-4 psi below the full inlet pressure (at low flows).**

### Checking Standby Monitor Operation

- With flow going through the station, slowly increase the setting of the Operating regulator. When the pressure reaches the setpoint of the Monitor Regulator, the Monitor should take control and the interstage pressure should decrease to approximately 2-4 psi above the outlet pressure.
- Reduce the setting of the Operating Regulator back to the required outlet pressure. The interstage pressure should increase to 2-4 psi below the inlet pressure as the Operating Regulator regains control (at low flows).

### NOTES:

---

---

---

---

---

---

---

---

---

---

---

---

---

---

---

---

---

---

---

---

---

---

---

---

## START AND OPERATION (cont'd)

### Working Monitor

1. Purge any pressure in the station.
2. Set Pilots #1 and #2 to a setting above the desired set points.
3. Set the Pilot (#3) at a zero setting.
4. Slowly open the inlet block valve to station. The Second Stage Regulator should remain closed as a result of the Pilot #3 being set to zero.
5. Fully open any hand valve(s) in the control line(s) and the Pilot supply line.
6. Open an outlet block valve or vent to allow flow through the station.
7. Increase the setting of the Second Stage Regulator, Pilot (#3) to the desired monitor over-ride pressure set point of the station.
8. Lower the setpoint of the First Stage Regulator Pilot (#2) to the desired interstage pressure setting. The First Stage Regulator should begin to control the interstage pressure at the setpoint of Pilot #2.
9. Lower the setpoint of Pilot #1 to take control of the system (a pressure that will be slightly lower than the final monitor over-ride pressure).
10. Raise the setpoint of Pilot #3 to a maximum setting.
11. Raise the setpoint of Pilot #1 to maintain the exact monitor over-ride pressure set point.
12. Lower Pilot #3 to the desired station outlet pressure.

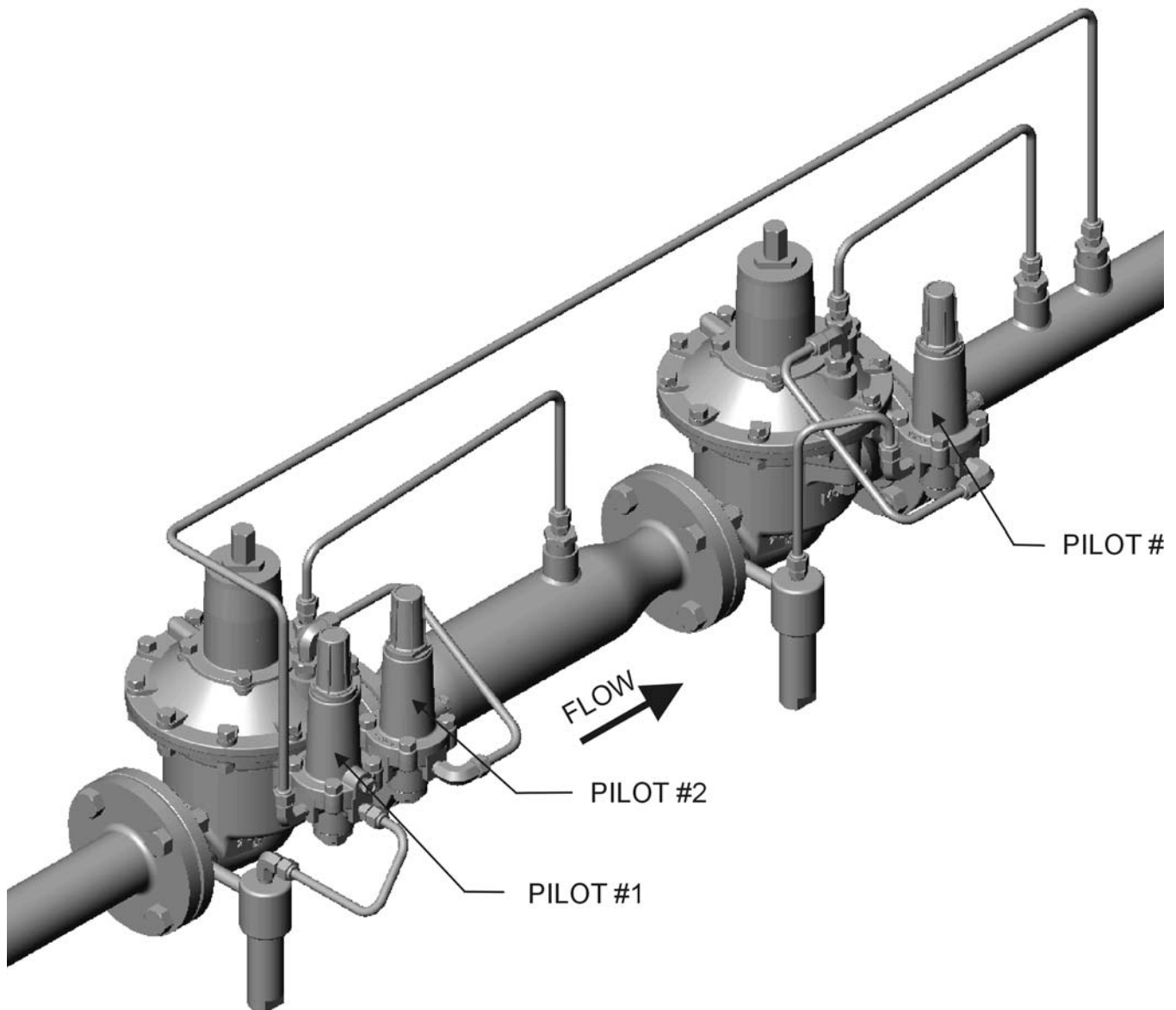

## MAINTENANCE

### WARNING

Installation and testing of the FlowMax® Regulator should be made by trained, qualified personnel familiar with high-pressure piping and Regulators.

Regulator parts are subject to normal wear and must be inspected and replaced as necessary. The frequency of inspection and replacement of parts depends on severity of service conditions or the requirements of local, state, and federal regulations. Be certain that the nameplates are updated to accurately indicate any field changes in equipment, materials, service conditions, or pressure settings.

**NOTE:** The Regulator and Actuator have been designed to facilitate the maintenance of the major wear components without the need to completely disassemble the Actuator.

### WARNING

Before disassembly make sure the regulator has been isolated from the process by closing block valves on the inlet and outlet sides of the regulator. Safely release pressure and process fluid from the system. Failure to complete these steps can result in personal injury and property damage.

#### Partial Disassembly for Stem/Plug/Seat Inspection

1. Disconnect Actuator Control/Sense and Pilot supply lines to the Actuator.



Fig 5. FlowMax® with tubing removed.

2. Loosen and remove the Cap Screws securing the Actuator Housing and remove the Actuator from the Body by lifting straight up. **DO NOT PRY.**



Fig. 6 Remove Actuator from Regulator Body.

3. Remove the Cage, Seat, Seat O-ring and Body Gasket. **NOTE:** The 6" FlowMax® does not have a body gasket. Inspect the Seat for damage. If any nicks, scratches, or other damage is present on the sealing surface (knife edge), the Seat must be replaced.

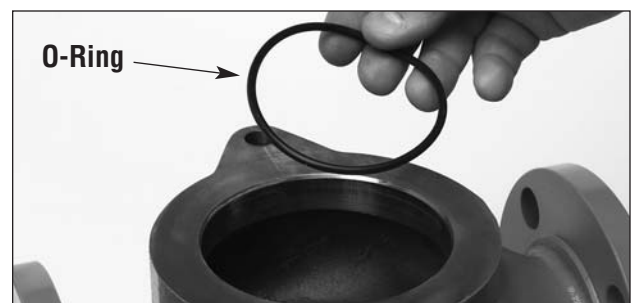
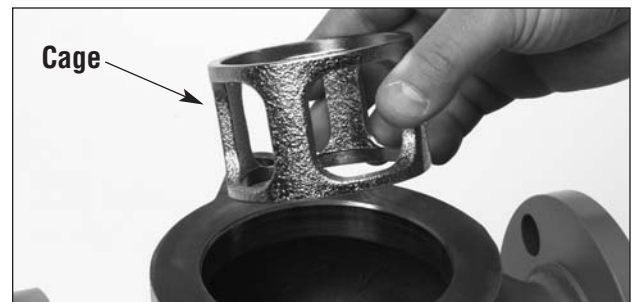

Fig. 7 Remove Cage, Seat, and O-ring.



## MAINTENANCE (cont'd)

### 6" FlowMax® Only

3. There is no body gasket in the 6" design. The cage needs to be unscrewed for removal. The housing o-ring should be removed and inspected.



Fig. 7a 6" FlowMax®: Remove Cage & inspect housing o-ring

4. Remove the Lower Stem Nut and remove the Plug Assembly.

**NOTE: When removing or tightening the Stem Nut, use a wrench on the Stem Flats to prevent the Stem from rotating and damaging the Main Actuator Diaphragm.**

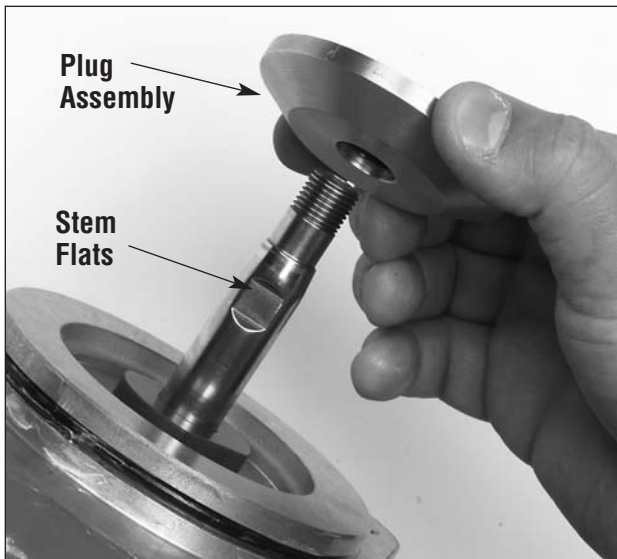

Fig. 8 Removing Plug Assembly from Actuator Stem.

5. Inspect the Plug Seal and Plug O-ring for damage or wear. If damaged, the Plug Seal may be turned over or replaced.

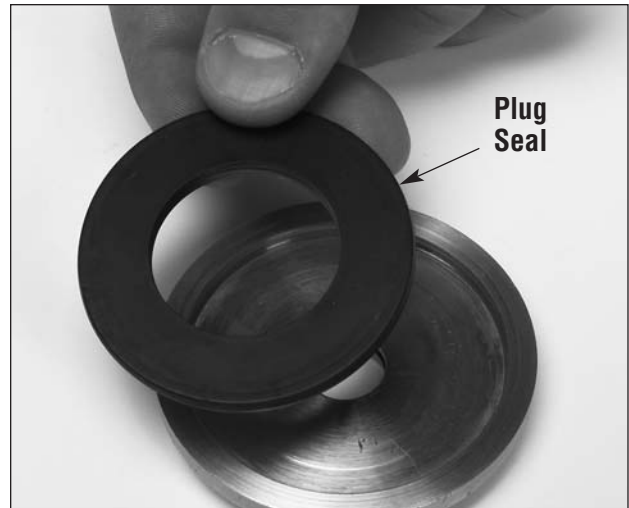

Fig. 9 Inspecting the Plug Seal.

6. Remove the Stem Bushing from the bottom of the Lower Actuator Housing. Use caution to not damage the sealing surface of the Stem.



Fig. 10 Removing the Stem Bushing.

7. Inspect the Stem O-ring in the internal groove of the Bushing for wear and/or damage. Reinstall Stem Bushing snug tight. Do not over torque.

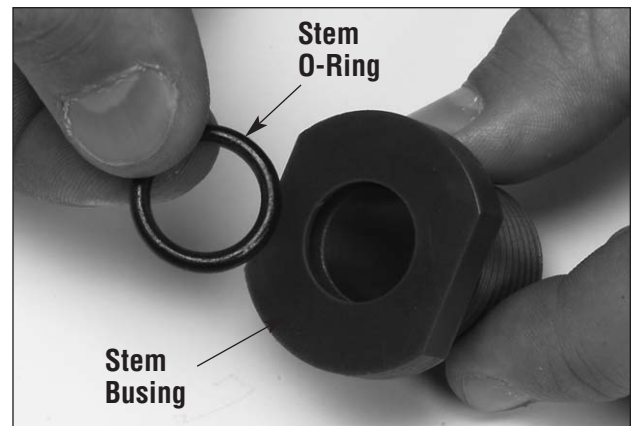

Fig. 11 Inspecting the Stem O-ring.

## MAINTENANCE (cont'd)

### Partial Assembly for Stem/Plug/Seat Inspection

**NOTE: Lightly lube O-rings before installation.**

1. If the O-rings have been removed, reinstall the Bushing O-ring and the Stem O-ring.
2. Screw the Stem Bushing into the bottom side of the Lower Actuator Housing until the Bushing flange has bottomed on the housing. **Do not over tighten.**
3. Install a new O-ring in the internal Plug groove.

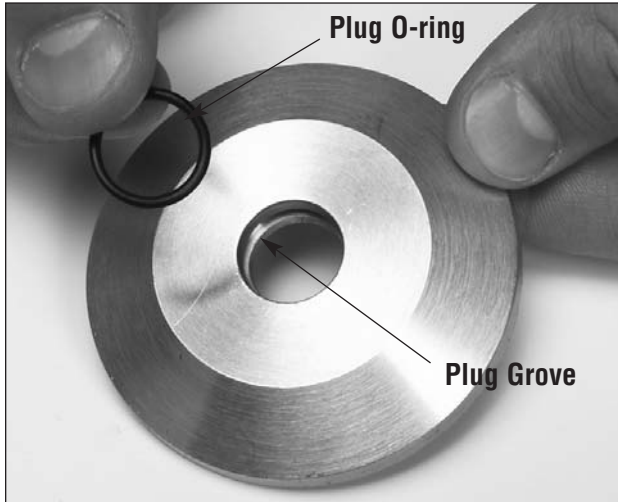

Fig. 12 Inspecting the Plug O-ring.

4. Install the Plug onto the tapered end of the Stem with the Plug Seal facing away from the Actuator.
5. Screw the Stem Nut on the bottom of the stem with the rubber seal toward the Plug to lock the Plug Assembly in place. **Use a wrench to hold the stem while tightening the stem nut.**



Fig. 13 Hold the Stem while tightening the Stem Nut.

6. Ensure that the Seat bore in the Body is clean and install the Seat O-ring and Seat into the bore in the Body. Make sure that the chamfered edge of the Seat is resting against the Seat O-ring and that the knife-edge sealing surface is facing up.

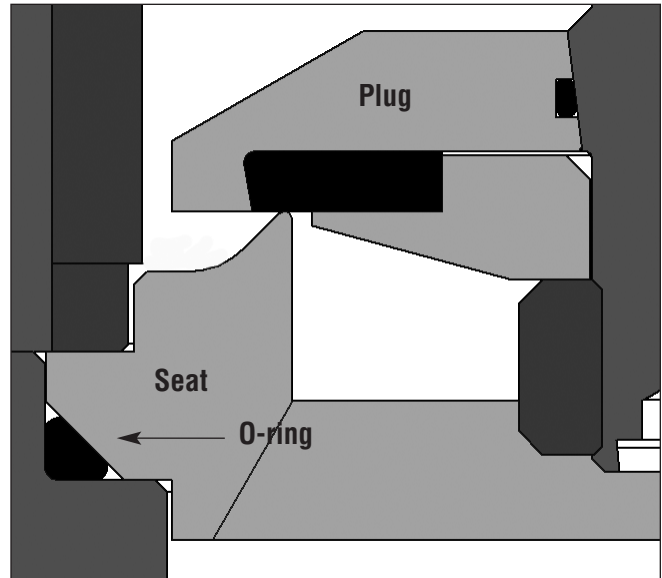

Fig. 14 Proper Seat Orientation.

7. Install the Cage onto the Seat. The Cage should fit snugly over the raised lip on the Seat. **Do not damage the Seat sealing surface when installing the Cage.**
8. Install the Body Gasket (2", 3" & 4" models). The 6" FlowMax® does not utilize a body gasket.

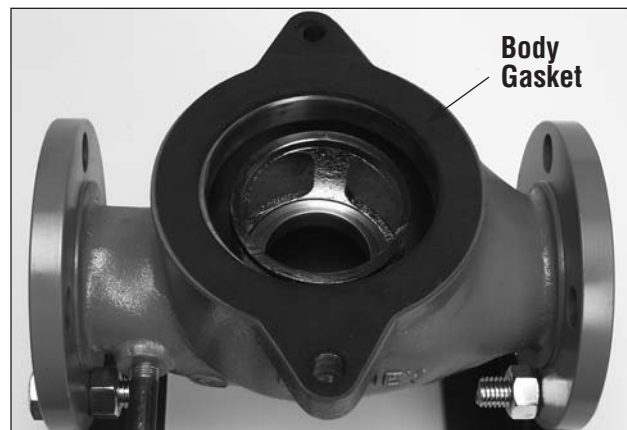

Fig. 15 Installing the Body Gasket.

9. Line up the mounting holes in the Body with those in the Lower Actuator Housing, and make sure that the Loading Port in the Lower Actuator Housing is facing towards the front of the Regulator. Apply a light coating of lubricant to the Housing O-ring and lower the Actuator Assembly onto the Body. **Use caution not to pinch the Housing O-ring during installation.**

## MAINTENANCE (cont'd)



Fig. 16 Installing the Main Actuator.

10. Incrementally tighten the Body Cap Screws to specified torque values. Table 4 Page 26.

### 2", 3" & 4" FlowMax® Only

**NOTE :** The gap between the actuator and body should be approx. 1/16 in.

### 6" FlowMax® Only

**NOTE:** The 6" FlowMax does not utilize a body gasket. There should be no gap between the actuator and body.



Fig. 17 Tightening the Body Cap Screws.

11. Reconnect Control/Sense and Pilot supply lines to the Actuator.

## Partial Disassembly for Balancing Diaphragm Inspection

1. Disconnect Control/Sense and Pilot supply lines to the Actuator.
2. Loosen the Spring Case Cap and remove the Main Spring.

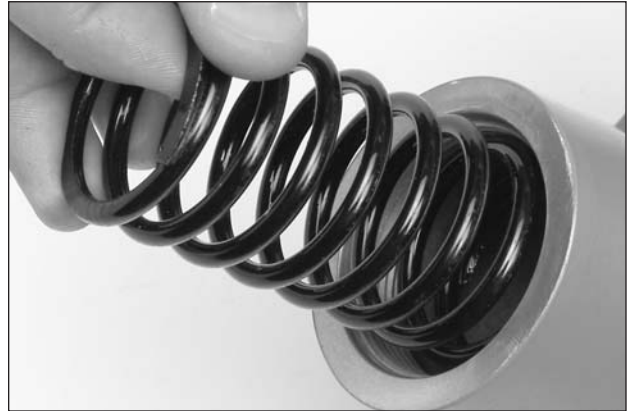

Fig. 18 Removing the Main Spring.

3. Remove the Spring Case Bolts, the Spring Case, and the Spring Case O-ring.

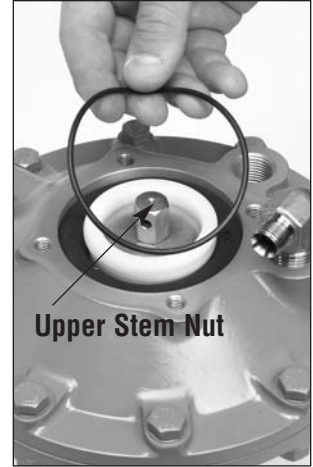

Fig. 19 Removing the Spring Case.

4. Remove the Cap Screws securing the Actuator Housing and remove the Actuator from the Regulator Body by lifting straight up. **DO NOT PRY.**
5. Remove the Upper Stem Nut located on top of the Piston. **When removing the Upper Stem Nut, hold the Stem with a wrench at the Stem flats near the Plug Assembly. Failure to do so may cause damage to the Main Actuator Diaphragm. Remove and inspect the Piston, Washer, and Balancing Diaphragm.** Inspect the Piston Ring and Balancing Diaphragm for signs of wear and damage. Replace as necessary.

## MAINTENANCE (cont'd)

### Partial Assembly for Balancing Diaphragm Inspection

1. Install the Balancing Diaphragm onto the Balancing Diaphragm Retainer. Ensure that the Diaphragm flange is facing up. Once installed, the top Diaphragm flange should be pushed down flush with the counter bore surface of the Upper Actuator Housing.

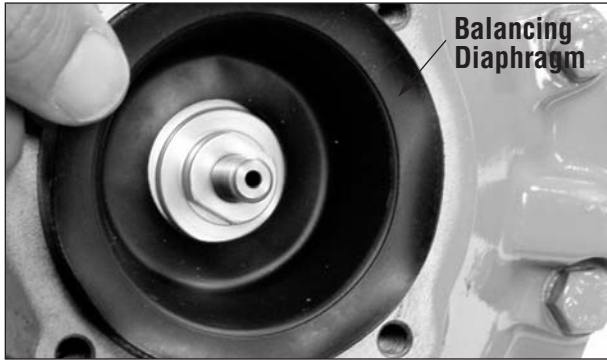

Fig. 20 Replacing the Balancing Diaphragm.

2. Install the Piston Ring onto the Piston.

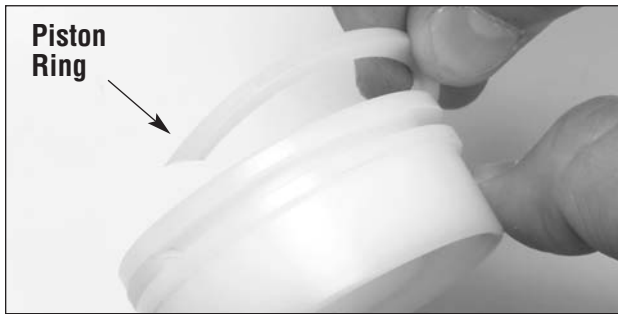

Fig. 21 Installing Piston Ring on Piston.

3. Install the Piston onto the Stem with the Piston Ring and counter bore up. The bottom end of the Piston should fit over the Balancing Diaphragm and hold it in place over the Balancing Diaphragm Retainer. **NOTE:** 3" -6" FlowMax® regulators utilize a nut to hold the Balancing Diaphragm Retainer in place.

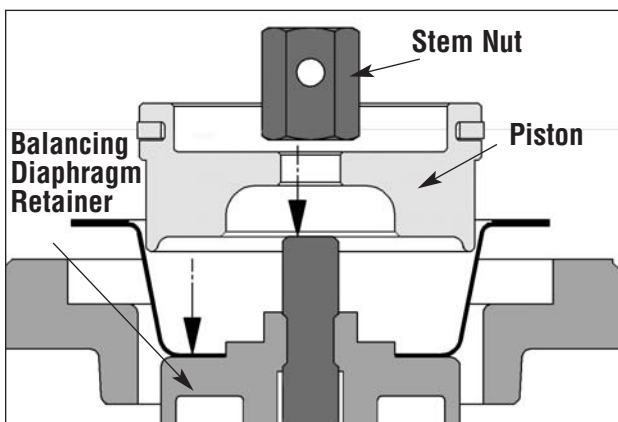

Fig. 22 Installing Piston over Balancing Diaphragm.

4. Install the Washer in the Piston counter bore and install the Upper Stem Nut. **Use a wrench to hold the Stem while tightening the Upper Stem Nut.**

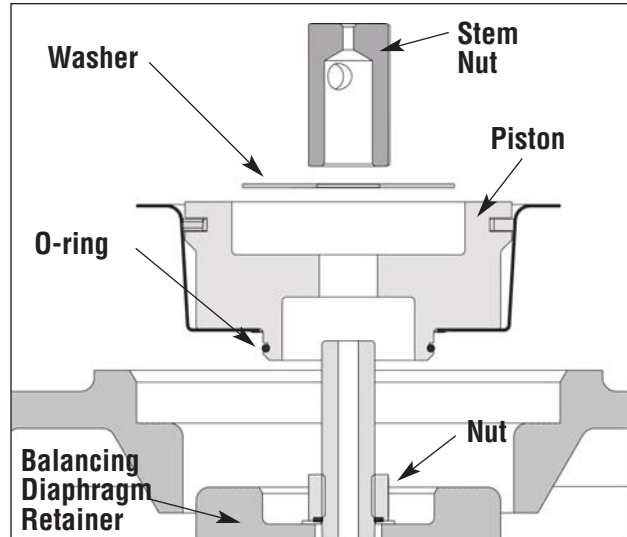

Fig. 22a 3"-6" FlowMax® only: Installing Piston and Balancing Diaphragm.

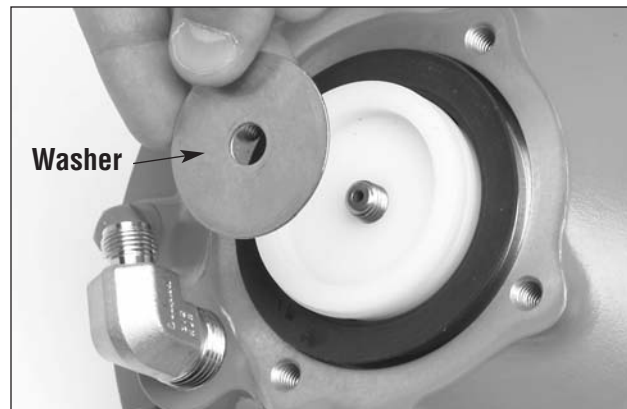

Fig. 23 Installing the Washer in the Piston Counter bore.

- 5a. **2" FlowMax® only:** Place the Balancing Diaphragm O-ring into the counter bore in the Upper Actuator Housing and install the Spring Case onto the Housing. The o-ring can be lightly stretched for ease of assembly.

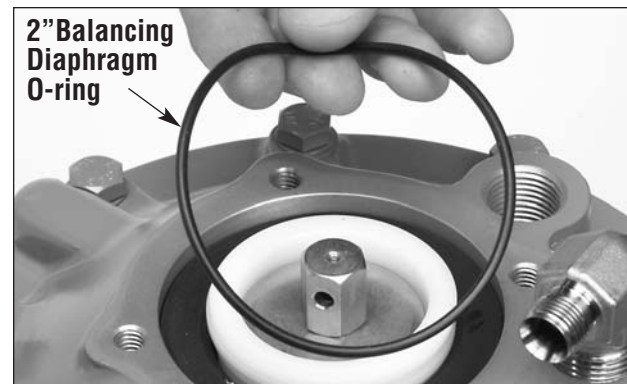

Fig. 24a Installing the Balancing Diaphragm O-ring on the 2" FlowMax®.

## MAINTENANCE (cont'd)

- 5b. **3", 4" & 6" FlowMax only:** Lubricate and install the Balancing Diaphragm O-ring into the Spring Case groove. Place the Spring Case onto the Housing and install Cap Screws to the proper torque (refer to Table 4, page 27).



Fig. 24b Installing the Balancing Diaphragm O-ring on the 3", 4" & 6" FlowMax®.

6. Insert the Main Spring into the Piston counterbore and install the Spring Case Cap. **NOTE:** The 6" FlowMax has an additional washer between the Spring and Spring Case Cap.



Fig. 25 Installing the Main Spring

7. Lightly coat the Housing o-ring with lubricant and install the Body Gasket. The 6" FlowMax does not utilize a body gasket, the Housing O-ring on a 6" FlowMax is machined into the valve body.



Fig. 26 Installing the Actuator on the Body.

8. Line up the mounting holes for the Body with those in the Lower Actuator Housing, and make sure that the Loading port in the Lower Actuator Housing is facing toward the front side of the Regulator.
9. Lower the actuator assembly onto the valve body. **Use caution not to pinch the housing O-ring during installation.**
10. Incrementally tighten the Body Cap Screws to specified torque values. Table 4 Page 27.



Fig. 27 Tightening the Body Cap Screws.

### 2", 3" & 4" FlowMax Only

**NOTE:** The gap between the actuator and body should be approx. 1/16 in.

### 6" FlowMax Only

**NOTE:** The 6" FlowMax does not utilize a body gasket. There should be no gap between the actuator and body.

11. Reconnect Control/Sense and Pilot supply lines to the Actuator.

### Disassembly for Main Diaphragm Inspection

1. Disconnect Control/Sense and Pilot supply lines to the Actuator.
2. Loosen and remove the Cap Screws securing the Actuator Housing and remove the Actuator from the Body by lifting straight up. **DO NOT PRY.**



Fig. 28 Removing the Main Actuator.

## MAINTENANCE (cont'd)

3. Remove the Spring Case Cap and remove the Main Spring.
4. Remove the Spring Case Capscrews and remove the Spring Case.
5. Remove the Upper Stem Nut and remove the Piston from the Stem. Remove the Balancing Diaphragm. **Use a wrench to hold the Stem while loosening the Stem Nut.**
6. Remove the Housing Cap Screws and remove the Upper Actuator Housing..



Fig. 29 Removing the Housing Cap Screws.

7. Remove the Balancing Diaphragm Retainer. Use a wrench to hold the Stem while loosening the Retainer. The 2" inch FlowMax® retainer is threaded and attached directly to the stem. The 3" - 6" FlowMax® regulators utilize a nut and washer to hold the retainer in place.



Fig. 30 Removing the Balancing Diaphragm Retainer.

8. Remove the Upper Diaphragm Retainer and the Main Diaphragm. Inspect the Main Diaphragm for any damage.
9. Inspect the Main Diaphragm Stem O-rings in the Upper and Lower Retainers for damage and replace if necessary.



Fig. 31 Inspecting Stem O-ring.

## Assembly of Main Diaphragm

1. Install the Main Diaphragm Stem O-ring into the internal groove of the Lower Diaphragm Retainer with the Stem still in place in the Lower Actuator Housing. The groove should be facing up. Install the Retainer on the stem.



Fig. 32 Installing Lower Diaphragm Retainer.

2. The main diaphragm is a top hat design and should be installed with the large flange down. Install the Main Diaphragm on the stem until it is bottomed on the lower Diaphragm Retainer.
3. Install the Upper Diaphragm Retainer over the threaded end of the stem so it is resting on the top side of the Main Diaphragm.

## MAINTENANCE (cont'd)

4. Install the Balancing Diaphragm Retainer o-ring side down, over the Stem and tighten. **Use a wrench to hold the Stem while tightening the Retainer.** The 2" inch FlowMax® retainer is threaded and attached directly to the stem. The 3" - 6" FlowMax regulators utilize a nut and washer to hold the retainer in place.
5. Align the small hole on the Main Diaphragm flange with the Alignment Pin in the Lower Actuator Housing and bottom the Diaphragm on the Housing flange.

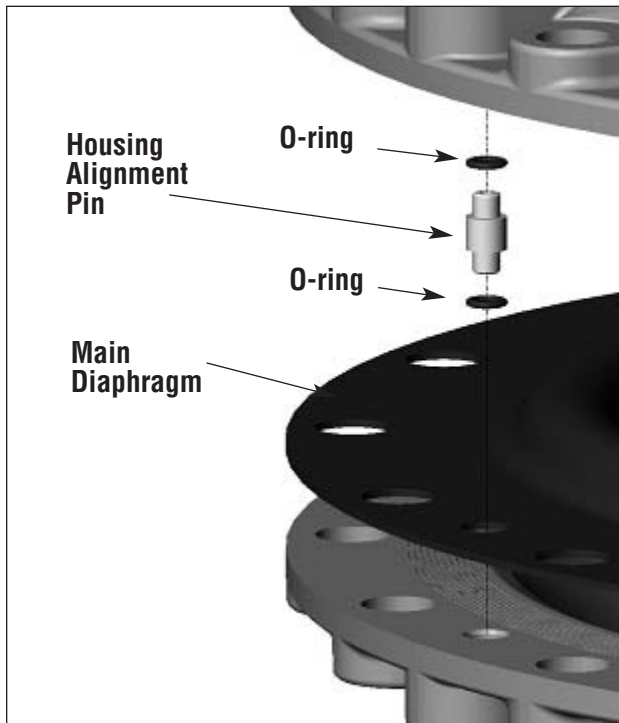

Fig. 33 The Housing Alignment Pin assembly for FlowMax® actuator assemblies.

6. Install the Upper Housing onto the Lower Housing and Diaphragm. Ensure that the Alignment pin engages the Alignment hole in the Upper Housing.
7. To hold the assembly in place, install at least two of the Housing Cap Screws on opposite sides of the Housing and tighten finger tight.
8. Move the Stem Assembly through full stroke. The Stem should move freely.

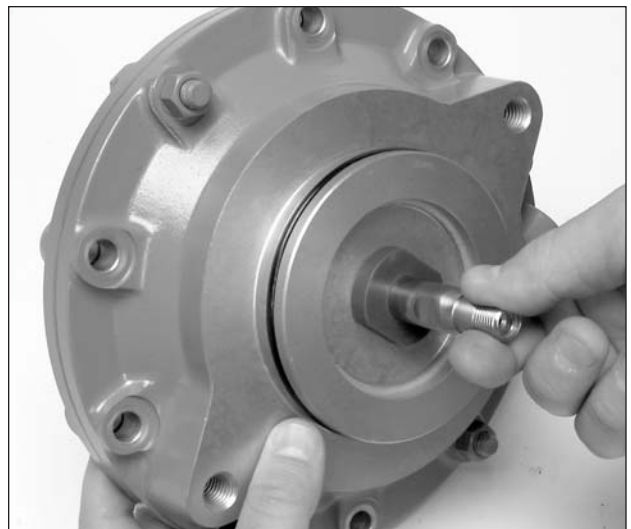

Fig. 34 Checking Stem for free movement.

9. Install and tighten the remaining actuator bolts per the torque recommendation (Table 4, Page 27).



Fig. 35 Install the remaining actuator Cap Screws.

## MAINTENANCE (cont'd)

10. Install the Balancing Diaphragm onto the Balancing Diaphragm Retainer. Ensure that the Diaphragm flange is facing up. Once installed, the Diaphragm flange will need to be pushed down so that it is flush with counter bore surface of the Upper Actuator Housing.



Fig. 36 Replacing the Balancing Diaphragm

11. Install the Piston Ring onto the Piston.

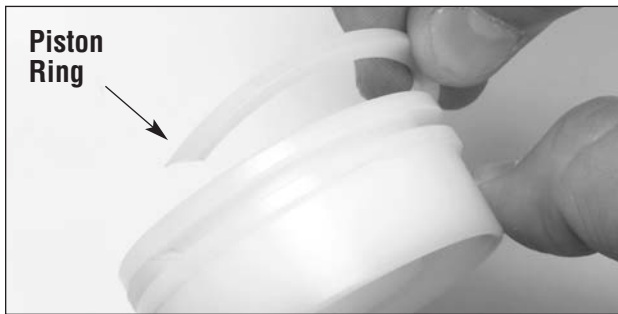

Fig. 37 Installing Piston Ring on Piston.

12. Install the Piston onto the Stem with the Piston Ring and counter bore up. The bottom end of the Piston should fit over the Balancing Diaphragm and hold it in place over the Balancing Diaphragm Retainer. **NOTE:** 3" -6" FlowMax® regulators utilize a nut to hold the Balancing Diaphragm Retainer in place

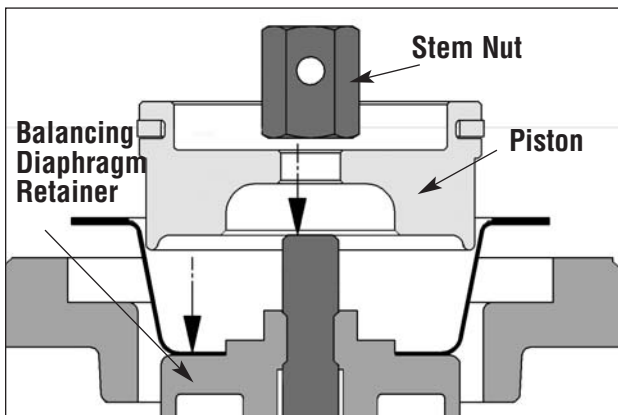

Fig. 38 Installing Piston over Balancing Diaphragm.

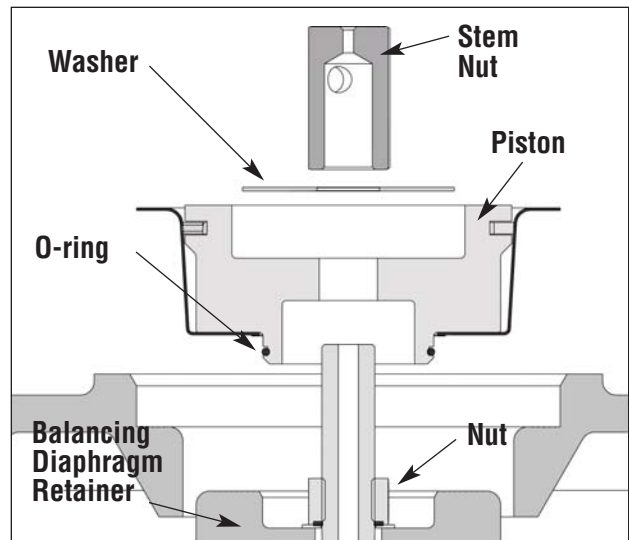

Fig. 38a 3"-6" FlowMax® only: Installing Piston and Balancing Diaphragm.

13. Install the Washer in the Piston counter bore and install the Upper Stem Nut. **Use a wrench to hold the Stem while tightening the Upper Stem Nut.**

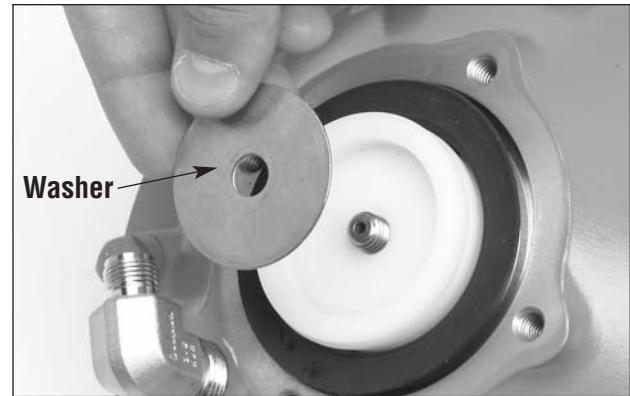

Fig. 39 Installing the Washer in the Piston Counter bore.

- 14a. **2" FlowMax® only:** Place the Balancing Diaphragm O-ring into the counter bore in the Upper Actuator Housing and install the Spring Case onto the Housing. The O-ring can be lightly stretched for ease of assembly.

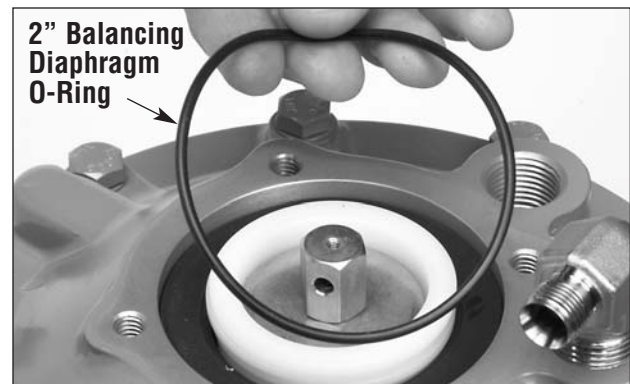

Fig. 40a. Installing the Balancing Diaphragm O-ring on the 2" FlowMax®.



**MAINTENANCE (cont'd)**

14b. **3", 4" & 6" FlowMax® only:** Lubricate and install the Balancing Diaphragm O-ring into the Spring Case groove. Place the Spring Case onto the Housing and install Cap Screws to the proper torque (refer to Table 4, page 27).



Fig. 40b Installing the Balancing Diaphragm O-ring on the 3", 4" & 6" FlowMax®

15. Insert the Main Spring into the Piston counterbore and install the Spring Case Cap.

**NOTE:** The 6" FlowMax has an additional washer between the Spring and Spring Case Cap.



Fig. 41 Installing the Main Spring

16. Lightly coat the Housing o-ring with lubricant and install the Body Gasket. The 6" FlowMax does not utilize a body gasket, the Housing O-ring on a 6" FlowMax® is machined into the valve body.



Fig. 42 Installing the Actuator on the Body.

17. Line up the mounting holes for the Body with those in the Lower Actuator Housing, and make sure that the Loading port in the Lower Actuator Housing is facing toward the front side of the Regulator.

18. Inspect, clean, and install the Seat O-ring, Seat and Cage into the Body.  
 19. Incrementally tighten the Body Cap Screws to specified torque values. Table 4 Page 27.



Fig. 43 Tightening the Body Cap Screws

**2", 3" & 4" FlowMax® Only**

**NOTE:** The gap between the actuator and body should be approx. 1/16 in.

**6" FlowMax® Only**

**NOTE:** The 6" FlowMax does not utilize a body gasket. There should be no gap between the actuator and body.

20. Reconnect Control/Sense and Pilot supply lines to the Actuator.

**NOTES:**

---



---



---



---



---



---



---



---



---



---

## MAINTENANCE (cont'd)

### Travel Indicator Kit Installation (Optional)

An optional Travel Indicator Kit is available for the FlowMax® regulator. Contained in the kit is an Indicator Stem, Indicator Stem O-ring, Indicator Stem O-ring Retainer, Spring Case Cap, Indicator Cover O-ring, and Indicator Cover. The following outlines the installation procedures for the kit. A pre-drilled and tapped Stem Nut currently exists as part of the FlowMax® regulator and is not included in the kit.



Fig. 42 Travel Indicator Kit

1. Remove the existing Spring Case Cap and Spring. Place a small amount of thread locking compound on the Indicator Stem threads. Finger tighten the Indicator Stem into the Stem Nut until bottomed. **Use caution to not damage the Indicator Stem sealing surface.**

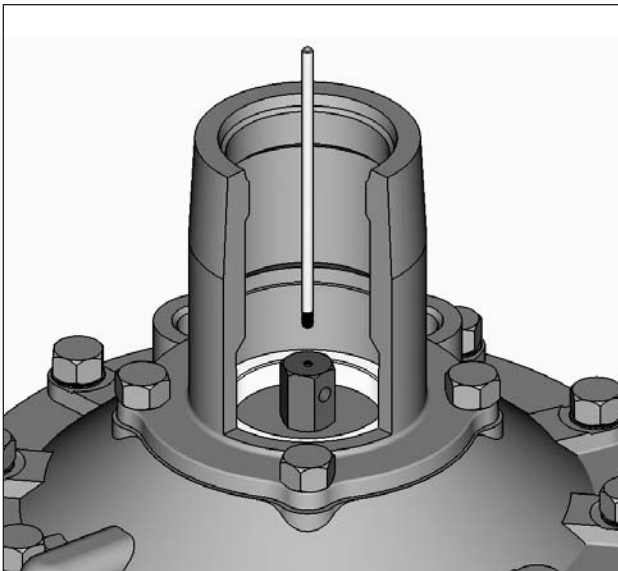

Fig. 45 Installing the Indicator Stem into the Stem Nut

2. Lubricate and insert the Indicator Stem O-ring into the small counterbore in the bottom of the new Spring Case Cap.

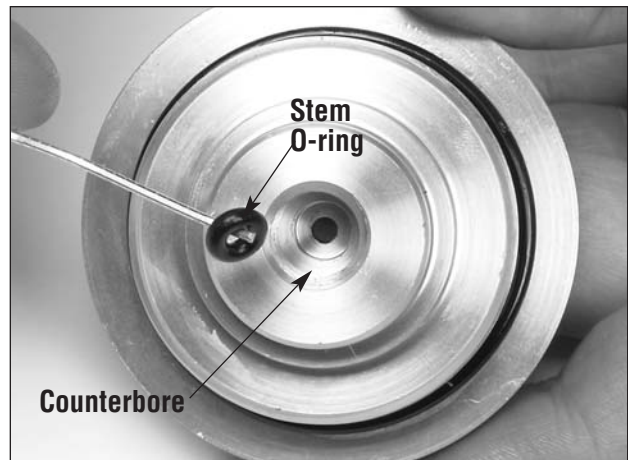

Fig. 46 Installing the Indicator Stem O-ring.

3. Install the threaded Indicator O-ring Retainer into the Spring Case Cap until bottomed. **Check to ensure the Indicator Stem O-ring is installed correctly and there is a visible hole through the Cap.**

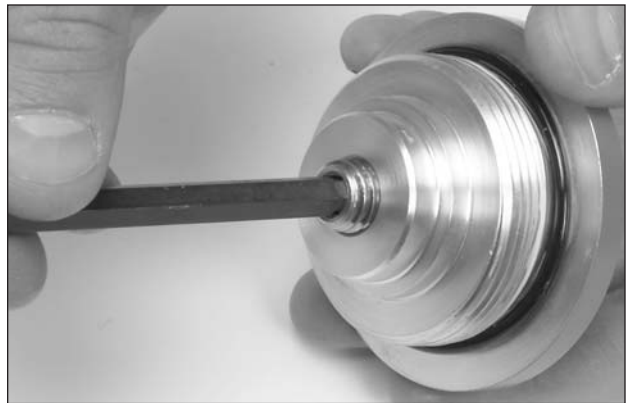

Fig. 47 Installing the O-ring Retainer

4. Reinstall the Main Spring. Install the Spring Case Cap O-ring and lightly lubricate the O-ring and threads. Thread the Spring Case Cap onto the Spring Case until bottomed. **NOTE:** The 6" FlowMax has an additional washer between the Spring and Spring Case Cap.



Fig. 48 Installing the Spring Case Cap

## MAINTENANCE (cont'd)

5. Install the O-ring onto the Indicator Cover. Lightly lubricate the O-ring and threads. Screw the Indicator Cover into the Spring Case Cap until bottomed.

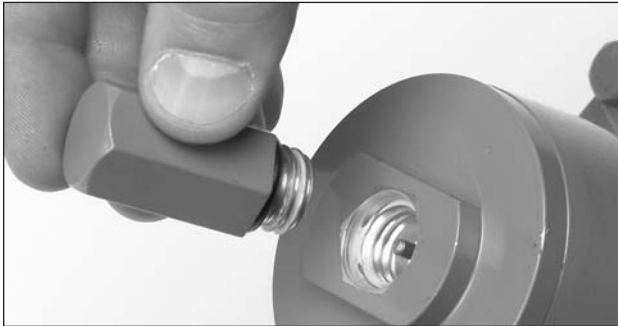

Fig. 49 Installing the Indicator Cover

### Installation of Reduced Capacity Trim

1. Disconnect the Actuator Control/Sense and the pilot supply tubing.
2. Remove the Cap Screws securing the Actuator Housing and remove the Actuator from the Body by lifting straight up. **DO NOT PRY.**



Fig. 50 Remove the Actuator Housing Assembly

3. Remove the stem nut. Use a wrench to hold the stem while loosening the stem nut.



Fig. 51 Remove the Stem Nut

4. Replace the Plug Retainer with the Reduced Capacity Plug Retainer.

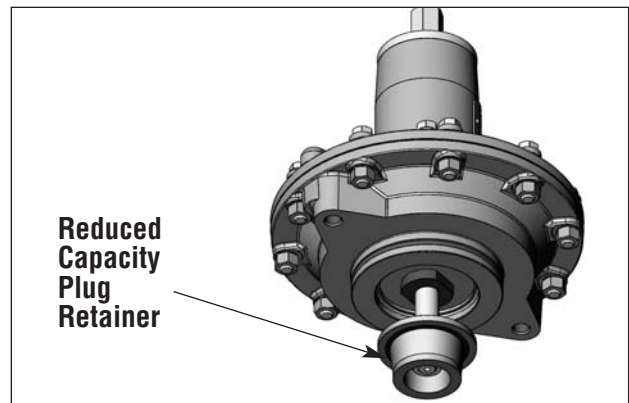

Fig. 52 Location of the Reduced Capacity Plug Retainer

5. Use a socket wrench to tighten the stem nut back onto stem. Use a wrench to hold the stem while tightening the stem nut.
6. Reassembly the actuator onto the valve body. Refer to steps 8-11 on pages 18 & 19.

### Cleaning

1. **DO NOT** clean O-ring grooves with sharp metal tools. The bottom of the grooves must have a smooth finish to prevent leakage. The mating surface of adjacent parts must also be smooth to prevent leakage.

Flow Max Bolting Torques (Lb-Ft)				
	2"	3"	4"	6"
Housing Cap Screws	6-7	10-12	10-12	15-16
Stem Nut	7-8	8-10	10-12	10-12
Spring Case	5-6	6-7	6-7	8-10
Plug Nut	7-10	7-10	7-10	7-10
Body Cap Screws	12-16	12-16	12-16	16-20

Table 4

## TROUBLESHOOTING

Problem	Solution
The regulator will not shut-off.	<ol style="list-style-type: none"> <li>1. Verify the clearance between the Actuator and Body is even.</li> <li>2. Check Actuator to Body bolts - tighten if necessary</li> <li>3. Check the Pilot for excess friction (“sticking open”).</li> <li>4. Check Main Spring</li> <li>5. Check the Plug Seal for damage</li> <li>6. Check the Seat for any nicks or damage to the sealing surface</li> <li>7. Check for damage to the seat O-ring</li> <li>8. Check for obstructions in the Stem hole</li> <li>9. Check for failure of the Balancing diaphragm</li> <li>10. Check for blockage of the internal restrictor</li> </ol>
Regulator will not open	<ol style="list-style-type: none"> <li>1. Check if any valves in the Sense line are not fully open</li> <li>2. Check the Pilot set point</li> <li>3. Check that existing piping matches the piping schematics</li> <li>4. Check for binding</li> <li>5. Check the Main Diaphragm for damage</li> </ol>
Erratic Behavior	<ol style="list-style-type: none"> <li>1. Check the location of the Sense line (away from pipes, fittings, and other turbulent locations)</li> <li>2. Check that the size of the Sense line is adequate (refer to recommendations on page 5).</li> <li>3. Check if any valves in the Sense line are not fully open</li> <li>4. Check the Pilot for excess friction (“sticking”)</li> <li>5. Check for excess friction in the Actuator</li> </ol>

## PRODUCT SUPPORT

Local support is available through our manufactures representative and distributor network. Contact the factory or refer to our web site for your support representative contact information. Factory support is available from 8:00AM to 4:30 PM MST Monday through Friday. Limited after hours support is also available. Complete product specifications, parts lists, and flow calculation software is available on our web site. [www.mooneycontrols.com](http://www.mooneycontrols.com) 801-487-2225 USA

## WARRANTY

**LIMITED WARRANTY:** Seller warrants title and that the goods manufactured by the Seller will be free from defects in materials and workmanship under normal use and service until the expiration of the earlier of twelve (12) months from the date of initial operation or eighteen (18) months from the date of shipment by Seller. Resale goods shall carry only the warranty extended by the original manufacturer to the original purchaser. If, within thirty (30) days after Buyer’s discovery of any warranty defects, Buyer notifies Seller in writing, Seller shall, at its option, promptly repair or replace F.O.B. point of manufacture, that portion of the goods found by Seller to be defective. Goods repaired and parts replaced during the original warranty period shall be in warranty for the remainder of the original warranty period. This warranty is the only warranty made by Seller and can only be amended by a written instrument signed by an officer of Seller. Subject to this warranty and except as expressly provided **IN SALES LITERATURE, GE MOONEY CONTROLS, GE INC. MAKES NO REPRESENTATION OR WARRANTY OF ANY KIND, EXPRESS OR IMPLIED, AS TO MERCHANTABILITY, FITNESS FOR PARTICULAR PURPOSE, OR ANY OTHER MATTER WITH RESPECT TO ANY OF THE PRODUCTS.**

While the information in this manual is presented in good faith and believed to be accurate, GE Pressure Regulation Group, GE Inc. does not guarantee satisfactory results from reliance on such information. GE Pressure Regulation Group, GE Inc. reserves the right, without notice, to alter or improve the designs or specifications of the products described herein.

**Mooney  
GE, Inc.**